

# **AQUA ENERGY DL HIGH PRESSURE**

**AQUA ENERGY INTERNATIONAL LTD**

28 St James Business Centre  
Linwood Road, Paisley PA3 3AT  
Scotland, UK

Tel: (+44) (0) 141 849 6888

Fax: (+44) (0) 141 848 5777

E-mail: sales@aquaenergy.com

www.aquaenergy.com

**INDUSTRIAL PLUNGER PUMP**



## **PUMP SPECIFICATIONS**

**Rated Horsepower** -----56

**Number of cylinders** -----3

**Plunger Stroke** -----40mm

**Oil Capacity** -----lt 3.80

**Plunger Dia** -----

**Pump Weight** ----- 63 Kg

### **Construction**

- Triplex plunger pump, available in 4 versions
- Patent pending, symmetrical power end design featuring top and bottom mounting holes allowing for easy left to right shaft conversion
- Pressure packing design with integrated cooling system
- Vertically fitted valves
- Splash lubrication

### **Material Quality**

- High resistance light alloy crankcase
- Stainless steel manifold
- Tapered roller rim bearings
- Special antifriction light alloy con rods
- Forged alloy steel crankshaft, hardened, tempered and nitrited
- Cast iron piston guide, nickel treated
- Sintered ceramic plungers
- Stainless steel valves

# DL-50 SERIES

## DIMENSIONS

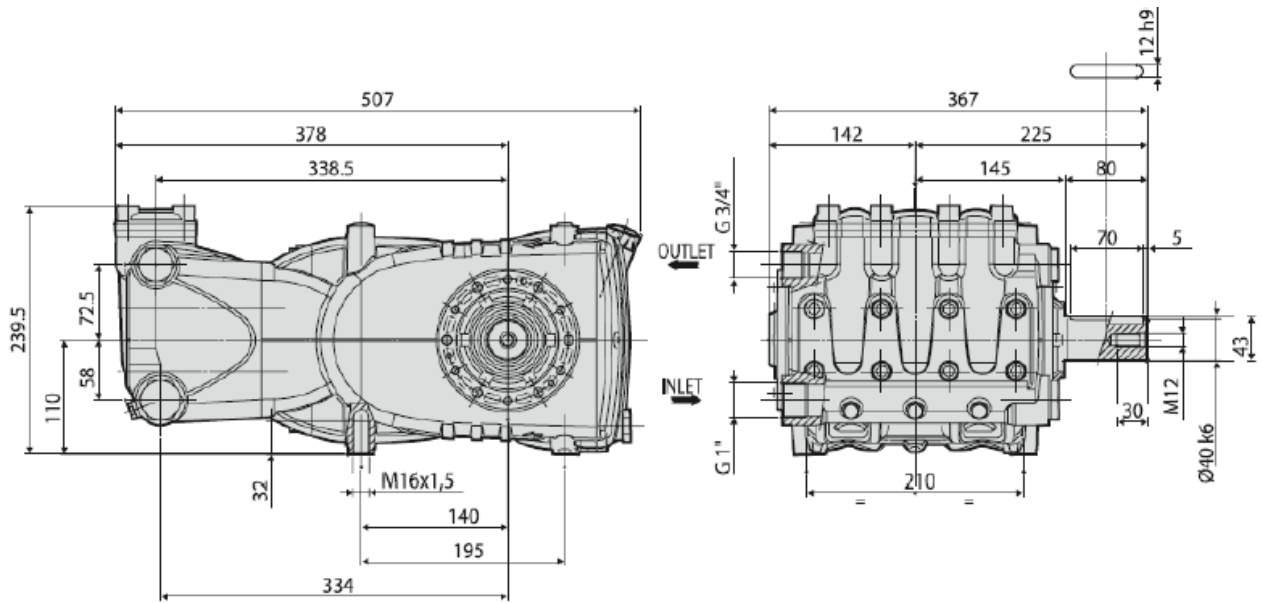

### DL 50 PUMP:

Maximum design pressure 600 bar (8700 psi)  
Maximum inlet pressure 3 bar (45psi)

**Standard connections:** Suction ----- G 1"  
Discharge ----- G 3/4"

Model	RPM	Volume		Pressure		Power		Stroke	50mm
		l/m	Gpm	Bar	Psi	HP	KW		
DL-50-28	1000	93	24.50	210	3,045	50	37.0	Max Inlet Pressure	3 bar (45 psi)
DL-50-30	1000	106	28.00	200	2,900	55	40.0	Oil Capacity	3,8 Litres
DL-50-32	1000	120	31.70	180	2,600	56	41.2		
DL-50-36	1000	153	40.00	130	1,900	52	38.2	Weight	63kg

Performances refer to theoretical delivery with 100% volumetric efficiency  
Under normal operating conditions pump volumetric efficiency is over 95%  
Please contact our technical staff in case of continuous and heavy-duty or special applications

Other versions available with pressures from 110 bar 160 bar.  
Water flows from 93.00 l/min to 170.00 l/min.  
Ask our technical staff for further information.

**For further information contact:** Aqua Energy International Limited  
St James Business Centre  
Linwood Road  
Paisley PA3 3AT, Scotland UK  
Tel: (+44) (0) 141 849 6888  
Fax: (+44) (0) 141 848 5777  
E-mail: sales@aquaenergy.com  
www.aquaenergy.com