

AQUA ENERGY

HAND HELD WALL CLIMBER PAINT & COATINGS REMOVAL

The 40,000psi (2,758bar) hand held WALL CLIMBER is designed to be the fastest manually operated Coatings Removal System on the market. The 190mm (7-1/2") wide cleaning path on the one-man operated unit removes the coatings and a vacuum recovery unit removes the spent water and old coatings from the work surface to a separation system for safe disposal.

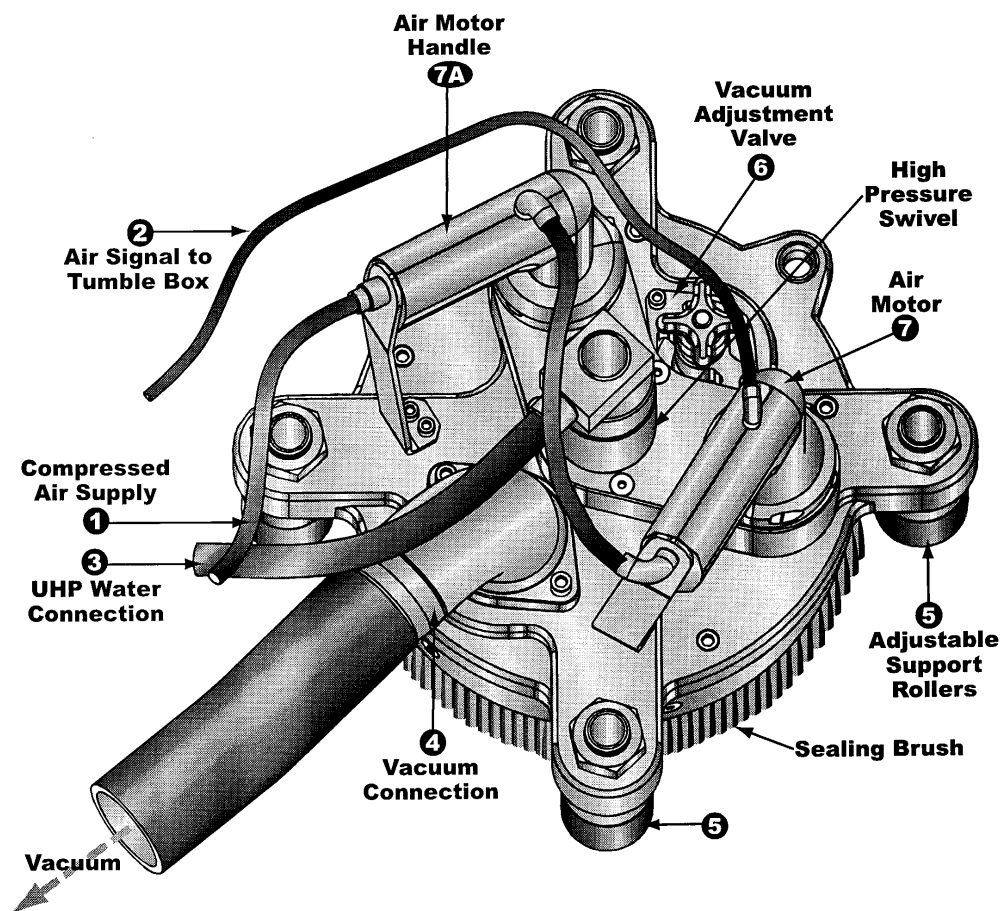

- Paint & Coatings Removal
- Ship Hull & Ballast Tank Stripping
- Gas & Oil Tank, Paint Stripping
- Pipe-line de-painting
- Offshore Platform Maintenance
- Concrete Cleaning & Scarifying
- Recovers old coatings through Vacuum extraction facility

Aqua Energy International Limited, St James Business Centre, Linwood Road
Paisley PA3 3AT, Scotland, UK

Tel: +44 (0) 141 849 6888 Fax: +44 (0) 141 848 5777

E-mail: info@aquenergy.com www.aquaenergy.com

AQUA ENERGY

TECHNICAL DETAILS

1. WALL CLIMBER REQUIREMENTS

The WALL CLIMBER must be driven by a 30,000 to 40,000 psi (**2,068 to 2,758bar**) Ultra High Pressure Water Jetting Unit and if required, a Vacuum System capable of producing a minimum of **450 SCFM at 8" Hg** to remove all Contaminated Water and Debris from the work surface. To work at optimum performance a Filtration/Separation Unit should also be used.

2. AIR SUPPLY

A dry compressed air compressor with a minimum flow of **30 SCFM at 100 psi (6.89 bar)** should be used. The incoming air supply # 1 on Fig 1 is connected to the left side air motor housing and the signal hose # 2 in fig 1 is connected to the right side air motor.

3. BALANCING THE WALL CLIMBER

The WALL CLIMBER weighs approximately 39.00lbs (**17.72Kg**). To enable easy manoeuvring, a spring-loaded Balancer-Tool is provided to take all of the weight off of the operator.

4. CONNECTIONS

The UHP Water Supply is connected to the **3/8" AE HP Female 90°** inlet block on the top of the swivel (see # 3 in fig 1. The Vacuum Hose must be at least **2" (50mm)** barbed type. The Vacuum connection swivels to minimise operator fatigue from dragging the Vacuum hose.

5. SPECIFICATIONS

Maximum Pressure: 40,000psi (**2,758bar**).

Maximum Water Flow: 7 gpm (**26.60 l-min**).

Maximum Rotation Speed of Cleaning arm: 3,000 rpm.

Minimum air Pressure: 100psi (**6.89 bar**) @ **30SCFM**.

Minimum Vacuum: 450 SCFM @ 8" Hg.

Maximum UHP Hose Length from Gun to Air Operated Valve: 25' feet (**7.57 metres**).

Recommended Maximum Water Filter Aperture for Water supply hose: **5 micron**.

Full set of counter Balance and Cables to take weight from operator.

Eight (8) Zero Degree Nozzles

Aqua Energy International Limited, St James Business Centre, Linwood Road
Paisley PA3 3AT, Scotland, UK

Tel: +44 (0) 141 849 6888 Fax: +44 (0) 141 848 5777

E-mail: info@aquenergy.com www.aquenergy.com